

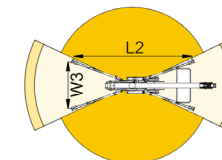

## BI-ENERGY

Diesel  
18,2 kW

Single-phase  
Electric motor  
230VAC - 2,2 kW

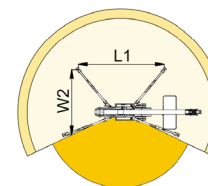
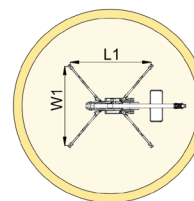
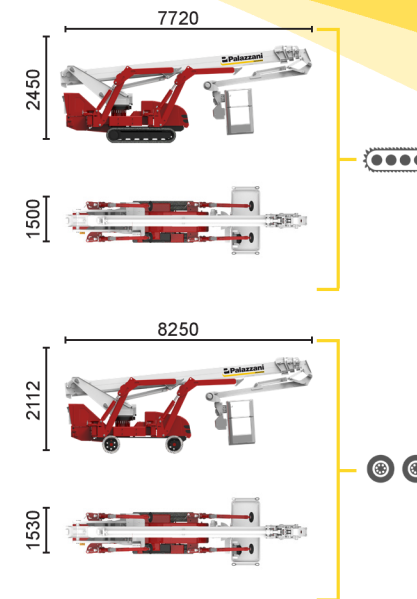
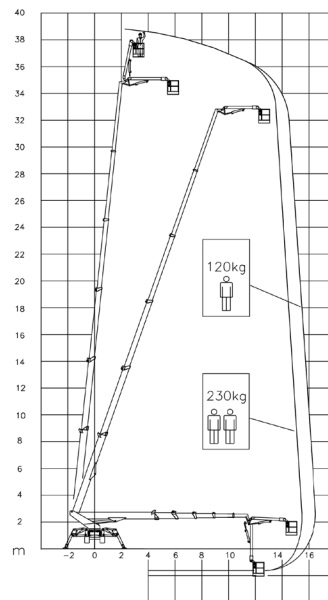
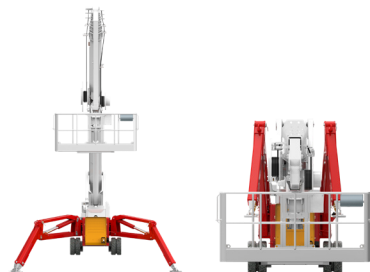

15,5 m	16,5 m	10 m	L1	L2	W1	W2	W3
230 kg	120 kg	230/120 kg	4960 mm	6200 mm	4700 mm	3810 mm	2920 mm



TSJ 39/C		39 m	16,5 m	230 kg	660°	240x70 cm	90°+80°	2,92-4,7 m	18%	40%	1,8 km/h	7960 kg	47 kN	3,41 kN/m <sup>2</sup>	4,3 kN/m <sup>2</sup>
TSJ 39/R		39 m	14,9 m	230 kg	660°	240x70 cm	90°+80°	2,92-4,7 m	31%	12%	1,4 km/h	7800 kg	47 kN	3,35 kN/m <sup>2</sup>	3,94 kN/m <sup>2</sup>

Available power options:

**BI-ENERGY** (DIESEL+AC)

**ECO** (AC+BATTERY)

**HYBRID** (DIESEL+AC+BATTERY)

Characteristics and technical data are informative only and subjected to change without notice.

**FILIALE MISSAGLIA:** Via I° Maggio, 25 - 23873 Missaglia (LC) - Tel: +39 039 92.011.61 - Tel: +39 039 92.011.62

**FILIALE SESTO SAN GIOVANNI:** Via G. di Vittorio, 338 - 20099 Sesto San Giovanni (MI) - Tel: +39 02 26224081

INFO LINE: 800.900.061

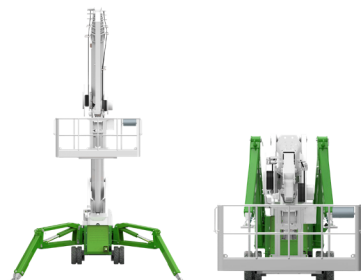

**ECO**

---

Single-phase  
Electric motor  
230VAC - 16 kW

---

Lithium iron  
phosphate battery  
LiFePO4  
48V - 315 Ah

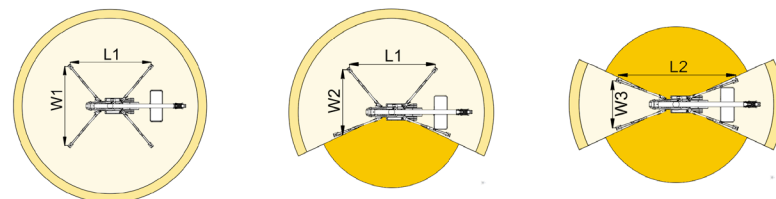
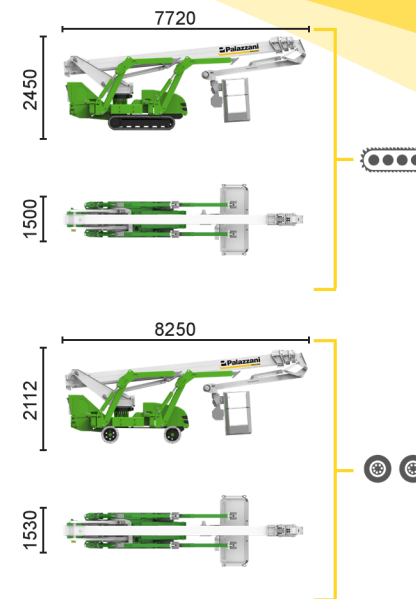
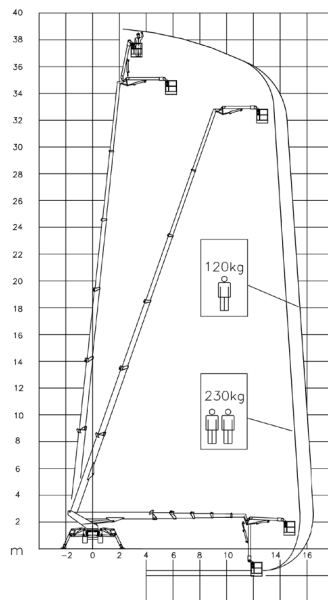

15,5 m	16,5 m	10 m	L1	L2	W1	W2	W3
230 kg	120 kg	230/120 kg	4960 mm	6200 mm	4700 mm	3810 mm	2920 mm



TSJ 39/C		39 m	16,5 m	230 kg	660°	240x70 cm	90°+80°	2,92-4,7 m	18%	40%	1,8 km/h	7960 kg	47 kN	3,41 kN/m <sup>2</sup>	4,3 kN/m <sup>2</sup>
TSJ 39/R		39 m	14,9 m	230 kg	660°	240x70 cm	90°+80°	2,92-4,7 m	31%	12%	1,4 km/h	7800 kg	47 kN	3,35 kN/m <sup>2</sup>	3,94 kN/m <sup>2</sup>

Available power options:

**BI-ENERGY** (DIESEL+AC)

**ECO** (AC+BATTERY)

**HYBRID** (DIESEL+AC+BATTERY)

Characteristics and technical data are informative only and subjected to change without notice.

**FILIALE MISSAGLIA:** Via I° Maggio, 25 - 23873 Missaglia (LC) - Tel: +39 039 92.011.61 - Tel: +39 039 92.011.62  
**FILIALE SESTO SAN GIOVANNI:** Via G. di Vittorio, 338 - 20099 Sesto San Giovanni (MI) - Tel: +39 02 26224081  
 INFO LINE: 800.900.061



## HYBRID<sup>2</sup>

Diesel  
14,7 kW

Single-phase  
Electric motor  
230VAC - 16 kW

Lithium iron  
phosphate battery  
LiFePO4  
48V - 315 Ah

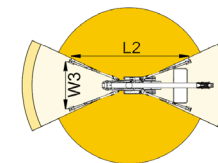
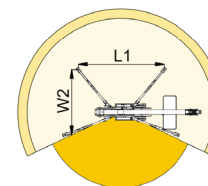
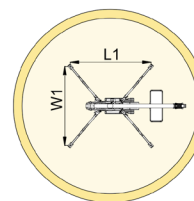
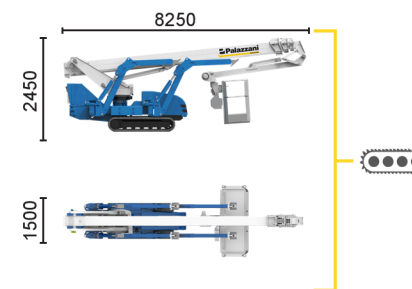
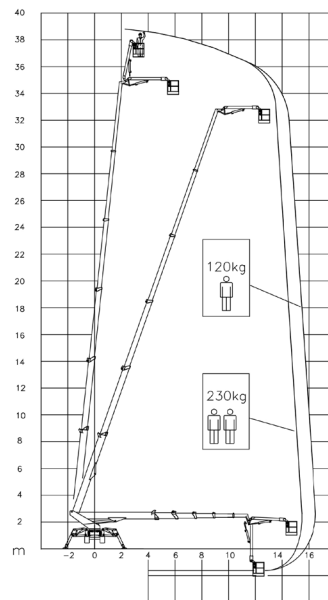
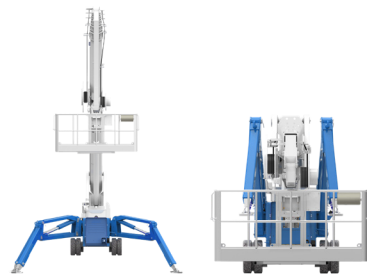

15,5 m	16,5 m	10 m	L1	L2	W1	W2	W3
230 kg	120 kg	230/120 kg	4960 mm	6200 mm	4700 mm	3810 mm	2610 mm



TSJ 39/C 39 m 16,5 m 230 kg 660° 240x70 cm 90°+80° 2,92-4,7 m 18% 40% 2,2 km/h 8100 kg 47 kN 3,47 kN/m<sup>2</sup> 4,09 kN/m<sup>2</sup>

Available power options:

**BI-ENERGY** (DIESEL+AC)

**ECO** (AC+BATTERY)

**HYBRID<sup>2</sup>** (DIESEL+AC+BATTERY)

Characteristics and technical data are informative only and subjected to change without notice.

**FILIALE MISSAGLIA:** Via I° Maggio, 25 - 23873 Missaglia (LC) - Tel: +39 039 92.011.61 - Tel: +39 039 92.011.62

**FILIALE SESTO SAN GIOVANNI:** Via G. di Vittorio, 338 - 20099 Sesto San Giovanni (MI) - Tel: +39 02 26224081

INFO LINE: 800.900.061